

DRAWING MADE IN THIRD ANGLE PROJECTION
 THIS DRAWING IS UNPUBLISHED. RELEASED FOR PUBLICATION
 © COPYRIGHT 19 BY AMP INCORPORATED, HARRISBURG, PA. ALL INTERNATIONAL RIGHTS RESERVED. AMP PRODUCTS MAY BE COVERED BY U.S. AND FOREIGN PATENTS AND/OR PATENTS PENDING.

LOC		DIST		P		F		ZONE		LTR		REVISIONS		DATE	APPD
BD	77												DESCRIPTION	15 DEC 95	RT
													E	REV PER EC 0020-983-95	

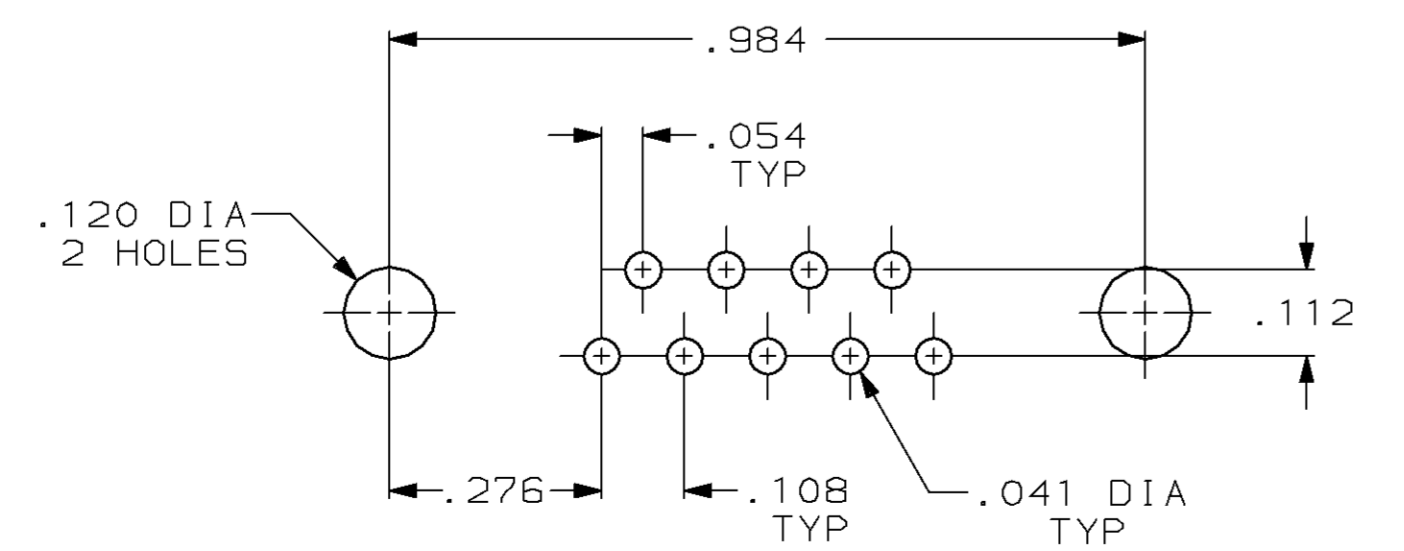
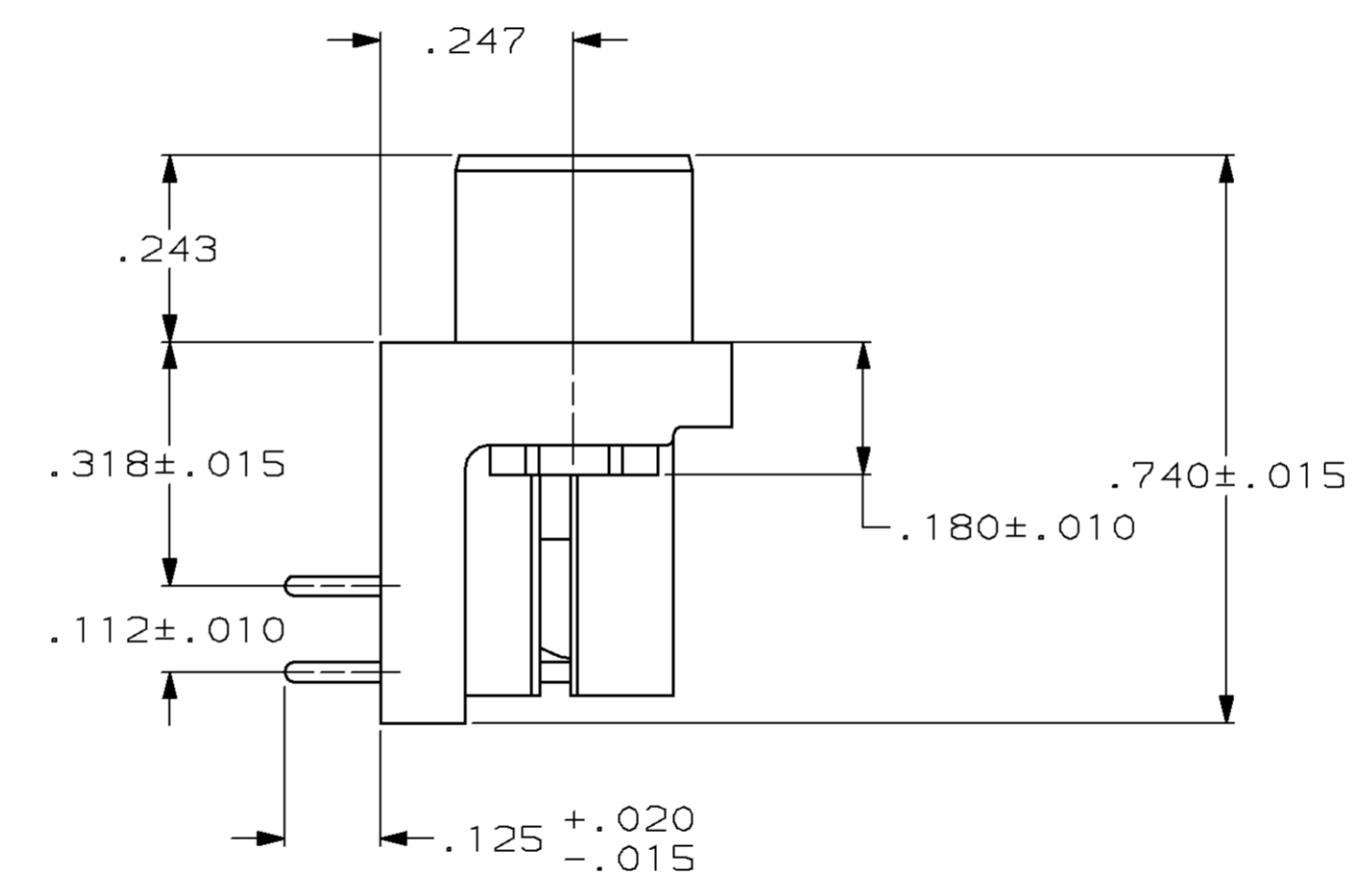
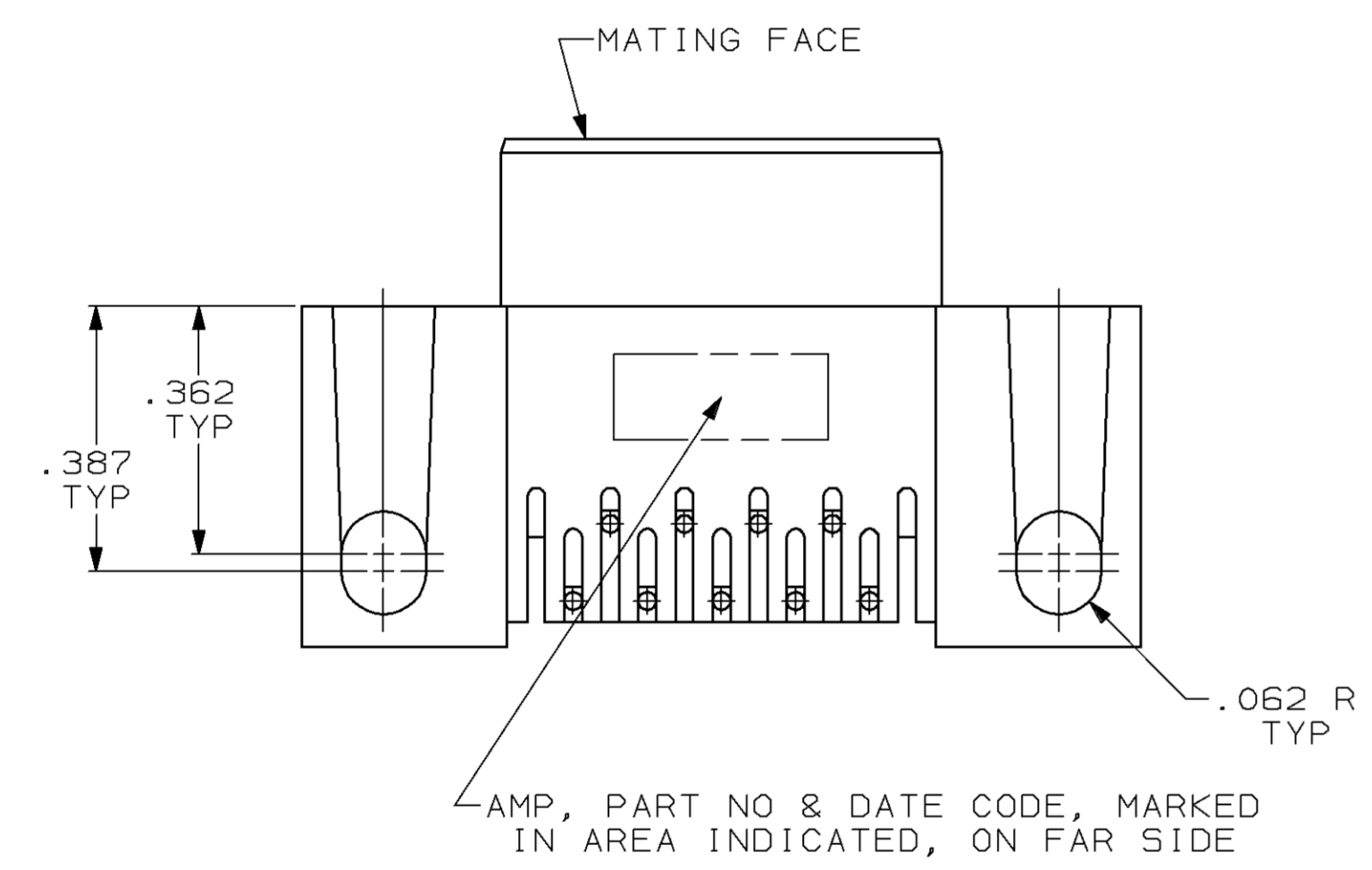
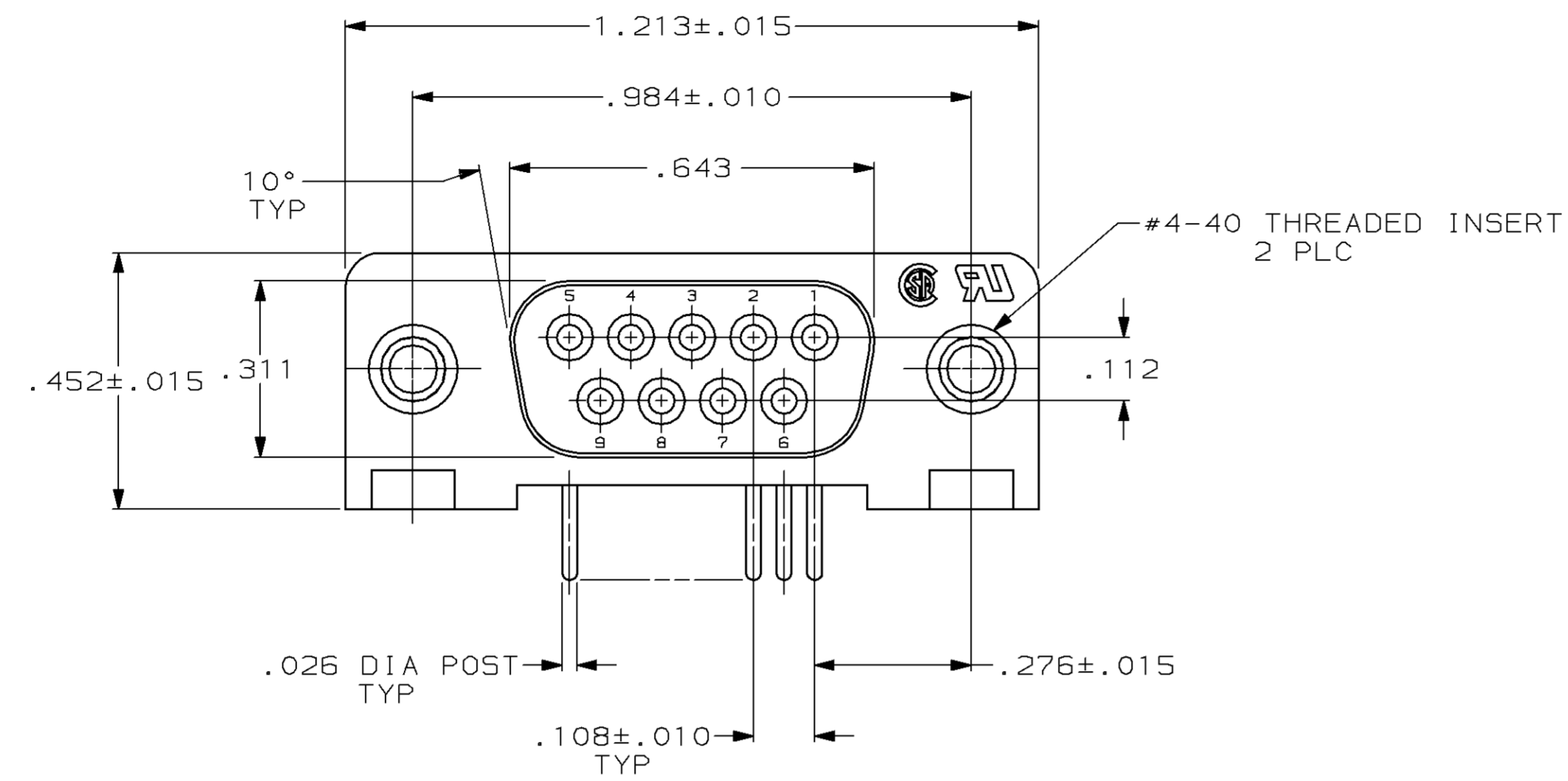

P.C. BOARD MOUNTING DIMENSIONS

- ① FLAME RETARDANT, 94V-0 RATED, GLASS FILLED NYLON OR POLYESTER, COLOR: BLACK.
- ② PHOS. BRONZE PER QQ-B-750.
- ③ REFER TO APPLICATION SPEC FOR RECOMMENDED P.C. BOARD MOUNTING DIMENSIONS FOR AUTOMATIC INSERTION.
- ④ GOLD PLATING PER MIL-G-45204, TIN PLATING PER MIL-T-10727, NICKEL PLATING PER QQ-N-290.
- ⑤ PLATED WITH GOLD FLASH FOR LENGTH OF .055 MIN FROM MATING END, WITH POINT OF MEASUREMENT .035 FROM MATING END OF CONTACT, .000100-.000200 TIN OR TIN-LEAD ON SOLDER END, ALL OVER .000050 NICKEL ON ENTIRE CONTACT.
- ⑥ PLATED WITH .000030 GOLD FOR LENGTH OF .055 MIN FROM MATING END, WITH POINT OF MEASUREMENT .035 FROM MATING END OF CONTACT, .000100-.000200 TIN OR TIN-LEAD ON SOLDER END, ALL OVER .000050 NICKEL ON ENTIRE CONTACT.

UNLESS OTHERWISE SPECIFIED DIMENSIONS ARE IN INCHES TOLERANCES ON:		DR 4-7-87 S. WELDON	AMP INCORPORATED Harrisburg, Pa. 17105
2 PL DEC ± .005 3 PL DEC ± .005 ANGLES ± 2°		CHK 4-14-87 C. RICHARD	
MATERIAL	MOLDED PARTS: ①	APPD 4-27-87 B. TAYLOR	NAME
CONTACTS: ②	INSERTS: ZINC	APPD 5-5-87 J. ASSINI	RECEPTACLE ASSY, SIZE 1, 9 POSN, RIGHT ANGLE, .318 SERIES, .026 DIA POSTS, W/ THREADED INSERTS, AMPLIMITE® HD-20
FINISH ④	CONTACTS: SEE TABLE	PRODUCT SPEC 108-40005	SIZE
INSERTS: CLEAR CHROMATE	INSERTS: CLEAR CHROMATE	APPLICATION SPEC 114-40015	FSCM NO 00779
		WEIGHT -	DRAWING NO 745394
		SCALE 4:1	SHEET 1 of 1