

THIS DRAWING IS UNPUBLISHED. RELEASED FOR PUBLICATION  
 © COPYRIGHT - By - ALL RIGHTS RESERVED.

LOC	DIST	REVISIONS					
G	14	P	LTR	DESCRIPTION	DATE	DWN	APVD
		G1		REVISED PER ECO-11-004917	11MAR11	RK	HMR

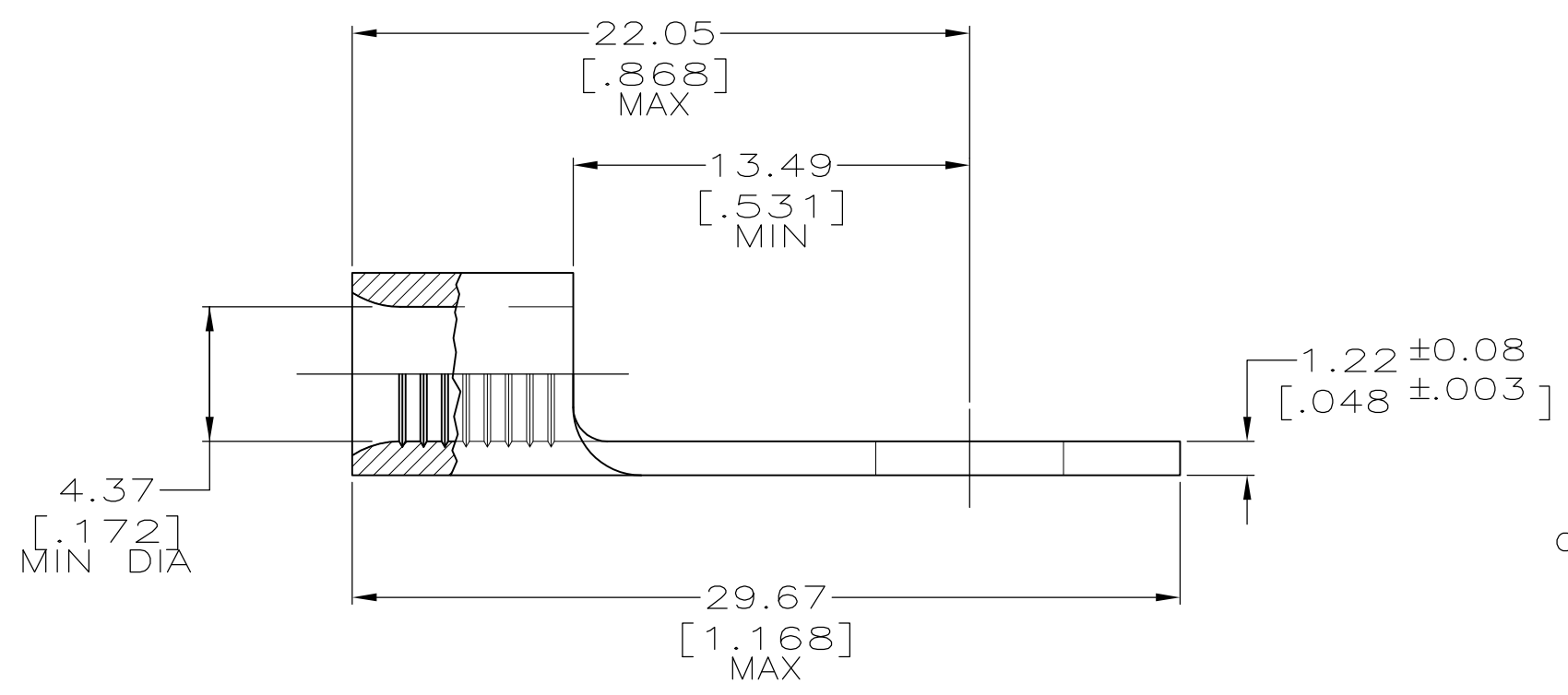
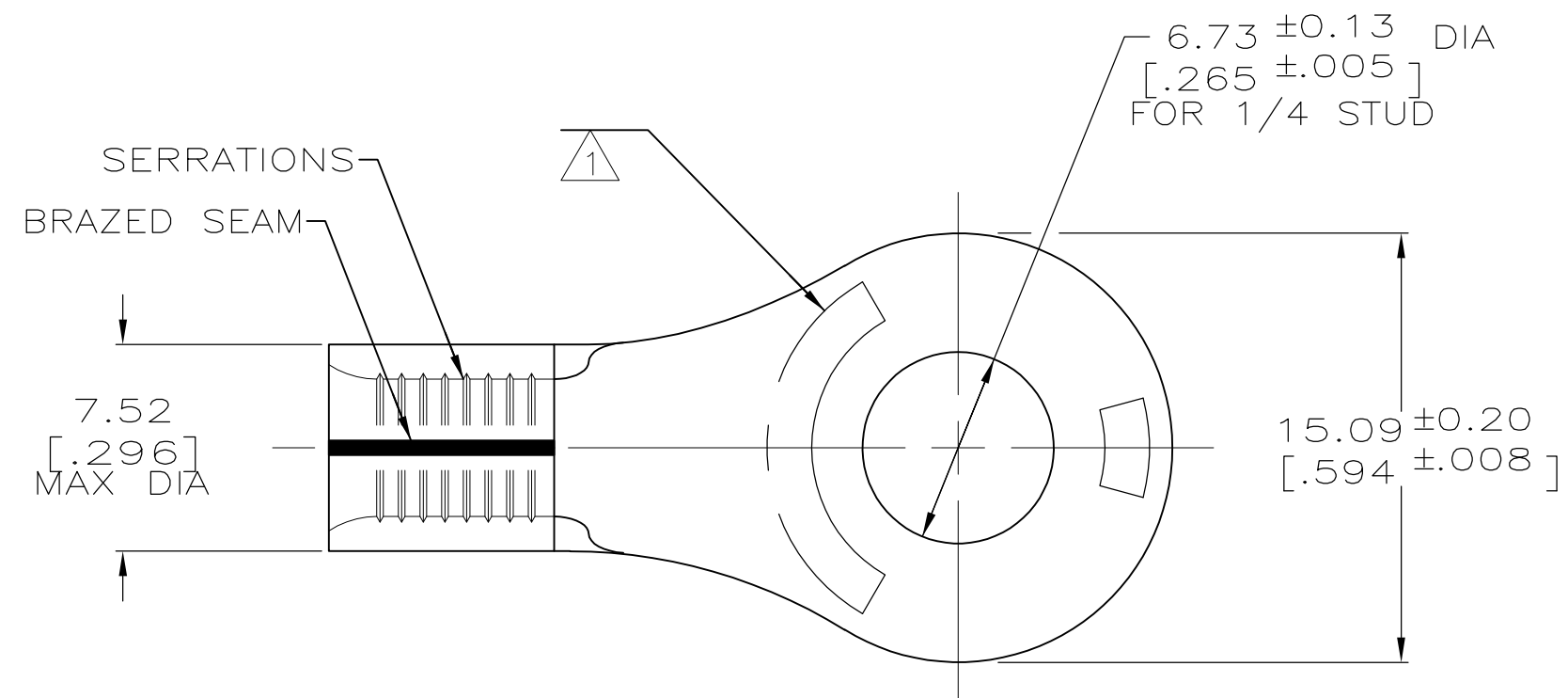

<b>AMP</b> WIRE RANGE	E13288 Listed
8 AWG SOLID OR STRANDED	8 AWG STRANDED
LR7189 Certified	MILITARY P/N AND CLASS
8 AWG SOLID OR STRANDED	NOT APPLICABLE

- ① STAMP AMP 8\* 14 APPROX AS SHOWN
- ② TIN PL 0.00254[.000100] MIN THK PER ASTM B-545
- ③ NICKEL PL 0.00162[.000300] MIN THK PER QQ-N-290
- ④ PRELIMINARY - NOT FOR PRODUCTION

OBSOLETE

50	LOOSE PIECE, BOX	-	8-35247-2
1,500	MOUNTED ON TAPE, REEL	② -	④ 2-35247-2
-	LOOSE PIECE	③ -	2-35247-1
-	LOOSE PIECE	② -	35247
QTY	PACKAGE TYPE	FINISH	AMP PART NUMBER

# AMP INCORPORATED CUSTOMER SERVICE SYSTEMS

FOR ADDITIONAL PRODUCT INFORMATION OR COPIES OF DRAWINGS AND TECHNICAL DOCUMENTS	PRODUCT INFORMATION CENTER 1-800-522-6752	RECOMMENDED OPERATING TEMPERATURE: 170° C MAX
FOR APPLICATION TOOLING INFORMATION	TOOLING ASSISTANCE CENTER 1-800-722-1111	VOLTAGE RATING: NOT APPLICABLE
FOR ORDER ENTRY	1-800-526-5142	WIRE CROSS SECTIONAL AREA RANGE: 6.64-10.50mm <sup>2</sup> [13,100-20,800] CIR MILS SOLID OR STRANDED

THIS DRAWING IS A CONTROLLED DOCUMENT.

DIMENSIONS: mm [INCHES]	TOLERANCES UNLESS OTHERWISE SPECIFIED:
	0 PLC ± -
	1 PLC ± -
	2 PLC ± -
	3 PLC ± -
	4 PLC ± -
	ANGLES ± -
MATERIAL COPPER PER ASTM B-152 ANNEALED	FINISH SEE TABLE

DWN DK SCHRUM 22AUG97	TE Connectivity	NAME		
CHK MJ SPICER 22AUG97		TERMINAL, RING TONGUE, SOLISTRAND™		
APVD JL MECKLEY 22AUG97		SIZE	CAGE CODE	DRAWING NO
PRODUCT SPEC		A3	00779	C-35247
APPLICATION SPEC	RESTRICTED TO	-		
WEIGHT	CUSTOMER DRAWING		SCALE 4:1	
	SHEET 1 OF 1		REV G1	