

Revision level		Revision Record	Changed	Date	Approved	Date
Drawing	Part					
00	-	SEE ECN# 012255	CJR	01/03/2013	CJR	01/03/2013

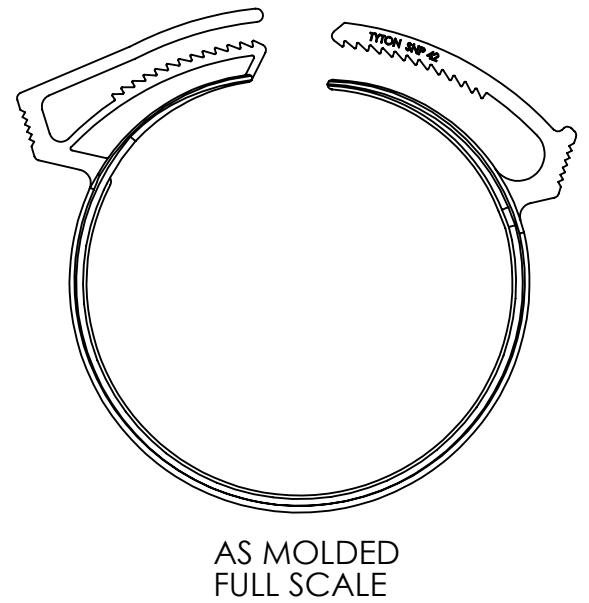
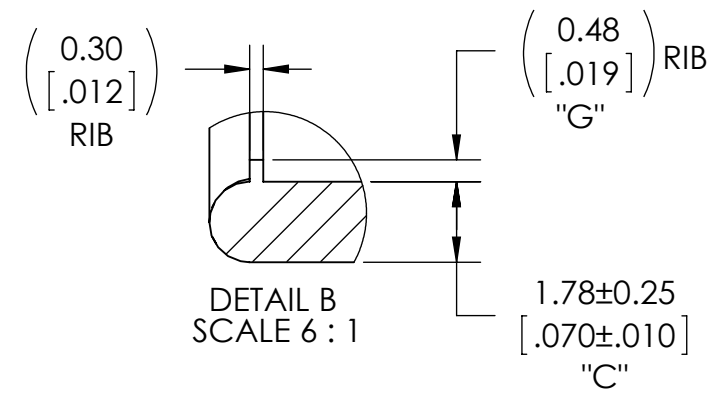
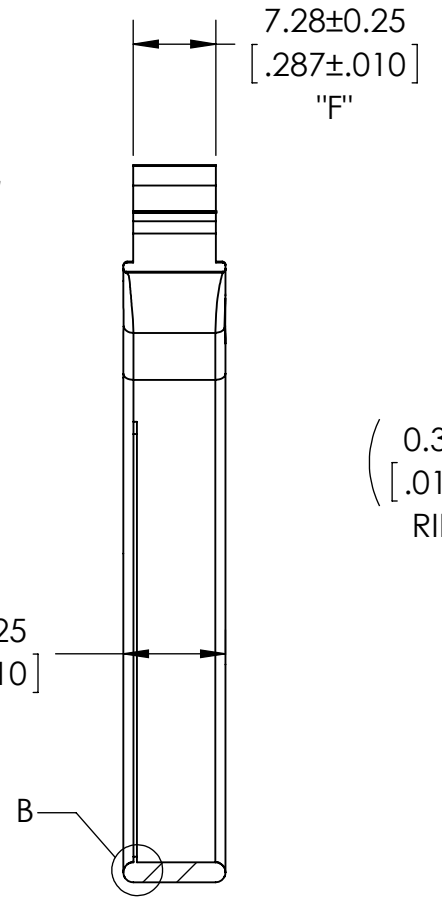
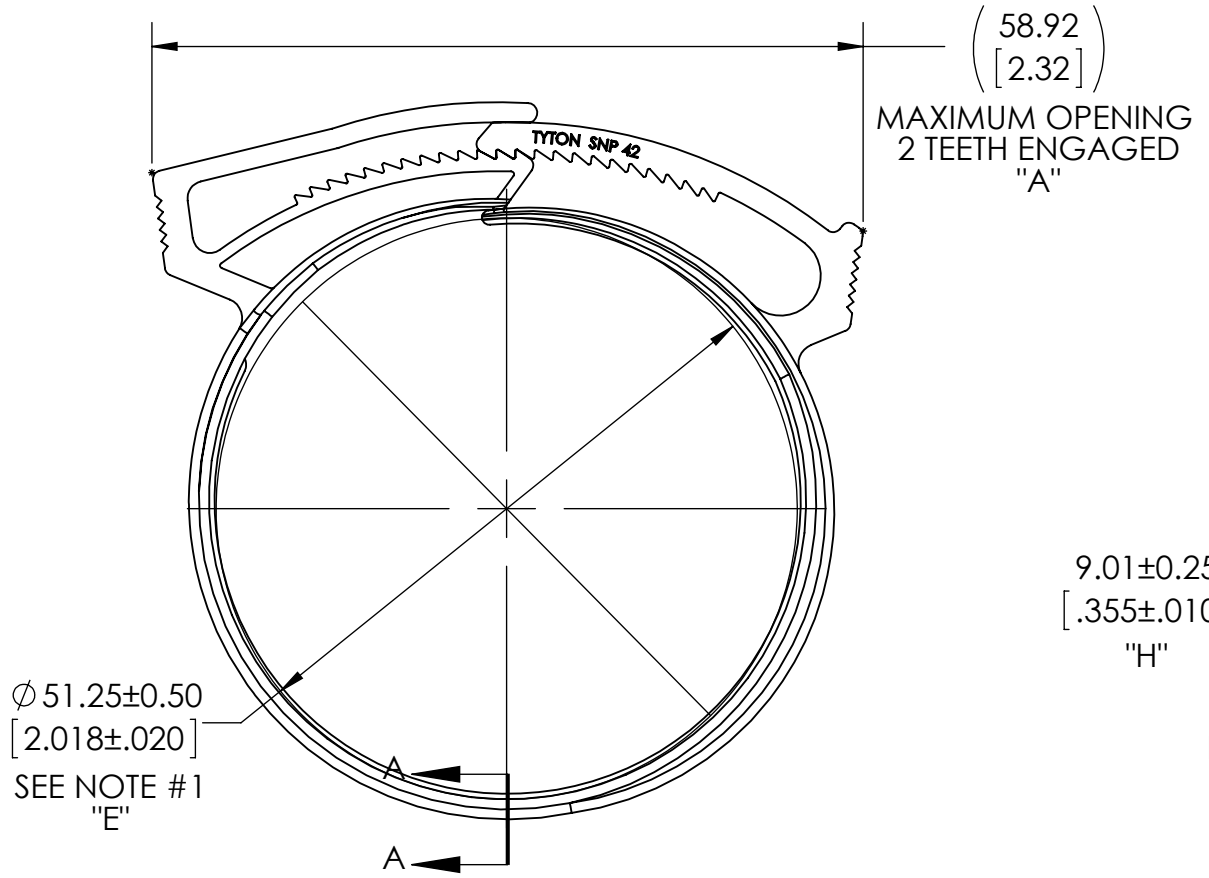
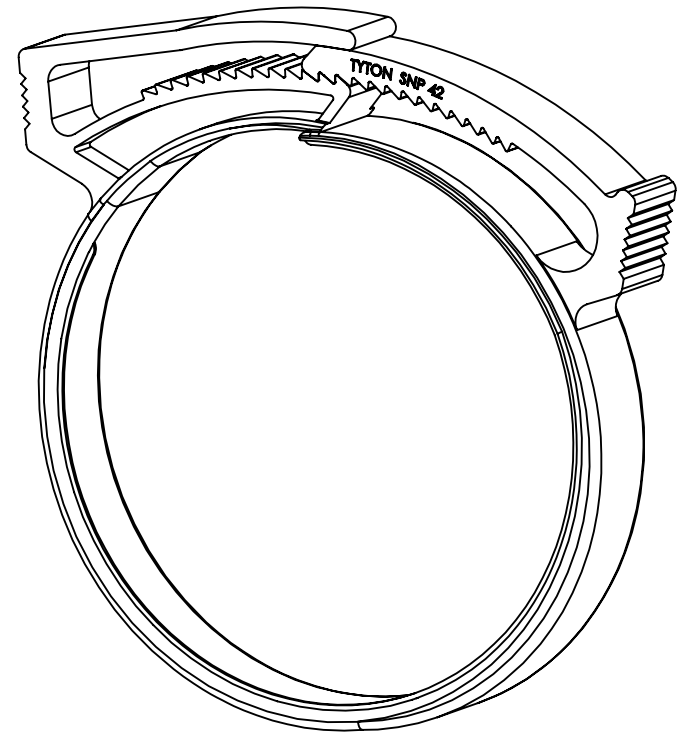
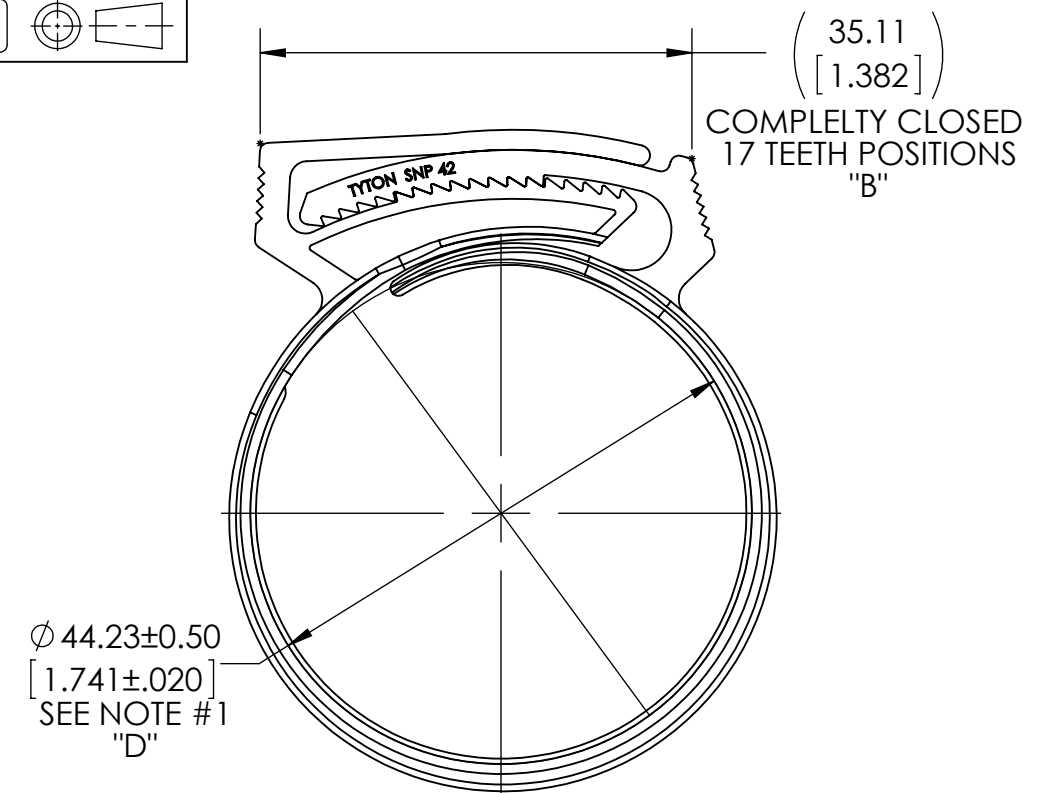

SECTION A-A

Notes
1) INSIDE DIAMETERS ARE MEASURED IN THREE PLACES SPACED 120 DEGREES APART EXCLUDING RIB.
2) 26 TOTAL TEETH, 17 TEETH POSITIONS.

Material
POM (ACETAL)

Units: millimeters
Dimension without tolerances details to:
.xxx = ±.013
.xx = ±.13
.x = ±.3
None = ±.8
∠ = ±0.5°
Dimension Formatted mm/[in]

The copyright of this drawing is reserved by HellermannTyton. It is issued on condition that it is not reproduced, copied, or disclosed to a third party, either wholly or in part, without the consent of HellermannTyton.

Drawn: CJR
01/03/2013
Approved: _____
HellermannTyton
North America
Email: corp@htamericas.com
Web: www.hellermann.tyton.com

Article/Type-No: SNP42
Title: SNAPPER 42 - HOSE CLAMP
Drawing-No: 13-0201-002-CSU
Concept : Phase

Scale: 1.5:1
Project Number: PRP13-0201
Format: B
Sheet: 1/1